

## 5. Power

- Battery is a SR44, 1.5V. Change the battery when voltage under 1.45V.
- Make sure the interface socket must not be plugged with SPC cable.
- Make sure the positive (+) side is up when changing new battery.



- If not used in about 5 minutes, the power will auto-off. The micrometer will wake up when pressing "ON/OFF" key or turning the spindle.
- Power off the micrometer by pressing "ON/OFF" key to save battery if not use.

## 6. Data output

- Data output interface is RS232C. The micrometer can be connected to PC's serial port through SPC cable P1104. The micrometer can be connected to PC's USB port through SPC cable P1502 or P1505. SPC cable P1505 is a plug-and-play device, which converts the measuring data to keyboard signal and inputs it to such software as Word or Excel etc.
- SPC cable P1104, P1502 and P1505 can connect an individual button P1601 or a pedal switch P1602.

Press the button or switch: Output the data to PC once, "G" flashes once.

Press and hold the button or switch more than 1 sec: Output the data to PC continuously and "G" keeps displaying. Press the button again to stop outputting.

- Output interface can be plugged into with our Bluetooth module P1802 and P1805 for wireless communication. The using of our Bluetooth module see its operation manual.

- Series port format:

2400 baud rate, 8 ASCII bits, 1 start bit, 1 stop bit.

- Data format:

Order	1	2	3	4	5	6	7	8	9	10
Metric	S	N1	N1	N	.	N	N	N	CR	LF
Inch	S	N	.	N	N	N	N	N	CR	LF

S: Minus or space

N1: Minus or space or digit 0-9

N: Digit 0-9

## 7. Specifications

Measuring force: 5~10N

Power consumption: <=25μA

Operating temperature: 0 ~ 40℃

Storage temperature: -20 ~ 60℃

Protection class: IP65 (protect water jetting)

## 8. Precautions

Do not subject the gauge to blows or knocks • Do not drop the gauge or apply excessive force to the gauge • Do not disassemble the gauge • Do not press the key with a pointed object • Do not use or store the gauge under direct sunlight, or in an excessively hot or cold environment • Do not subject the gauge in strong magnetic fields and high voltage environment • Use soft cloth or cotton cleaning the gauge. Do not use any organic solvent such as acetone etc. • The spindle is designed so that it cannot be removed from the inner sleeve. Do not move it past the upper limit of the measuring range • Remove the battery if the gauge not use for a long time

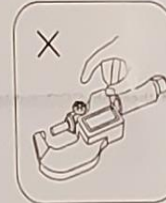

## 9. Trouble shooting

Failure	Causes	Repairing
Display "E 1" Display "Exxxx"	Measuring value over display range.	Reset the origin or convert to relative measuring mode.
Display "E 2"	The origin is too great.	Reset the origin.
Display "E 3" Display "E 8"	1. The micrometer is disturbed. 2. Something wrong with sensor.	1. Reset the battery. 2. Return the micrometer for repair.
Measuring value is inaccuracy	1. Measuring surfaces are dirty. 2. The origin isn't correct.	1. Clean measuring surfaces. 2. Reset the origin.
Display is confusing or dead	Suffer to strong disturb.	Reset battery.
Measuring value is wrong No display or display is blurring "☐" appears The output data is wrong	Battery voltage under 1.45V.	Replace battery.

# ELECTRONIC MICROMETER OPERATION MANUAL

## 1. Functional elements

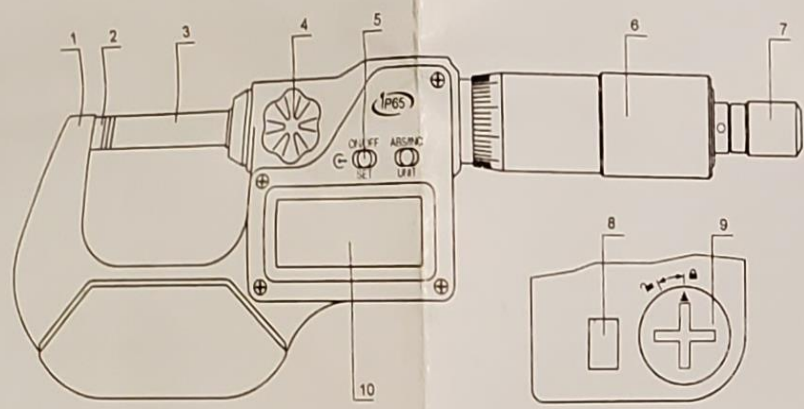

1. Frame
2. Anvil
3. Spindle
4. Locking device
5. Keys
6. Thimble (or ratchet friction thimble)
7. Ratchet stop (or quick drive)
8. Output port
9. Battery cap
10. LCD display

## 2. LCD Display



- in : Inch mode
- INC : Relative measuring
- ABS: Absolute measuring
- : Battery voltage is low
- : Data output to PC
- Set : Set the origin

## 3. Operation

Two ways of pressing key are used in the following illustration:

- (1) Press and release.
- (2) Press and hold (more than 1 sec.).

### 3.1 ON/OFF and SET key, or output key

- ON/OFF and SET key, when SPC cable not plug in
  - : ON/OFF Power on/off.
  - : SET Set the origin.
- Data output key , when SPC cable plug in
  - : Output the data to PC once, " flashes once.
  - : Output the data to PC continuously and " keeps displaying. Press the key again to stop outputting

## 3.2 ABS/INC and UNIT

- : ABS/INC Absolute/Relative measuring mode conversion.
- : UNIT Metric/Inch measuring mode conversion.

## 4. Set the origin

### 4.1 Set the origin (for normal micrometers.)

Press and hold "SET" key until "Set" flashes once on LCD and the display is set to the origin.

### 4.2 Set a new origin (only for 3-point internal micrometer and micrometer heads.)

- a. Press and hold "SET" key until "Set" flashes and the origin is displayed. Go to f if not changing the origin.
  - b. Press and hold "SET" key until "Set" stops flashing and the first digit starts flashing. The next digit will flash if not release the key until it is the digit desired.
  - c. Press "SET" key, the flashing digit +1 until it is desired.
  - d. Press and hold "SET" key until the next digit flashes.  
Repeat steps c and d until the data on LCD is desired.
  - e. Press and hold "SET" key until "Set" flashes.
  - f. Press "SET" key, the data on LCD will be set to the origin.
- The origin will not be lost after reset the battery.



### 4.3 Set a stepped origin (only for depth micrometer, gear root diameter micrometer, micrometer with adjustable anvils and micrometer with interchangeable anvils.)

- a. Press and hold "SET" key until "Set" flashes and the origin is displayed. Press and hold "SET" key, the display will be set to the origin if not changing the origin.
  - b. Press "SET" key, the displayed value will increase 25mm (or 1"); press "UNIT" key, the displayed value will decrease 25mm (or 1"). Origins for metric are 0, 25, 50, ... 975, 0 (for inch are 0, 1", 2", ... 39", 0). When displayed value is desired, press and hold "SET" key until "Set" disappears, the data on LCD will be set to the origin.
- The origin will not be lost after reset the battery.